

Kemlan

Coupe Series of Double Sided Wood Heaters



Kemlan Coupe Inbuilt



Coupe Inbuilt with Marble Margins (Side A)



Coupe Inbuilt with Marseilles Limestone Mantel & Hearth, Fascia Trim. (Side B)

The Kemlan Coupe Inbuilt /Insert is designed so each ceramic glass viewing area is flush fitting with the wall in each room. Designed for new or existing fireplaces.

Optional cast iron fascias are available for an old style finish.

The ceramic glass remains clean throughout the life of the fire by an advanced airwash system designed within the firebox. Choose from a range of colour options (see back of brochure).

Kemlan Coupe Inbuilt



— Beauty you can see through

Coupe Freestanding

A unique double sided wood heater, the Kemlan Coupe Freestanding is a valuable addition to modern open plan living. The strong ceramic glass viewing area remains clean throughout the life of the fire with the advanced air wash system designed within the firebox. Choose from a range of colours (see back page of brochure).

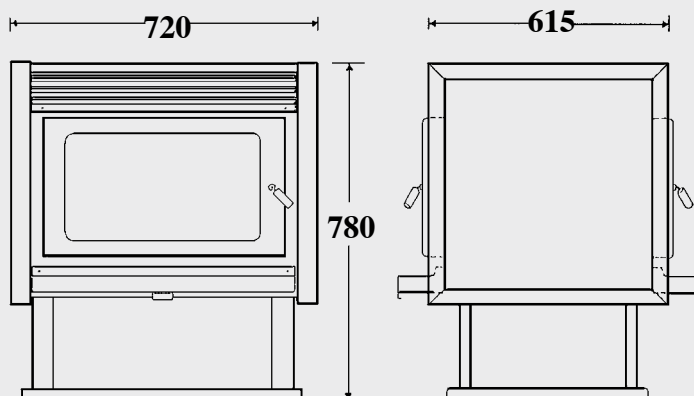

Clearances - Side Wall 350mm



Coupe Wall Penetration

–The Best of both worlds



Side A



Side B

The Kемlan Coupe Wall Penetration is a truly unique Double sided wood heater. Designed to be installed in a wall between two rooms with an inbuilt stylish modern or traditional feature on one side and a freestanding wood heater on the other. Choose from a range of colours. (see back of brochure)

Designed to be installed through an existing timber or single/double brick wall. Consult your local authorised distributor for specifications regarding installation.

U-section surround/lintel must be set into brick work or hebel block. Consult your local authorised distributor for the style to suit your application.

A floor protector is required where the floor is heat sensitive. Thickness to be a minimum of 14mm heat resistant material and must extend 300mm in front and 200mm to each side of the firebox openings.

Shipping weight 168kg.

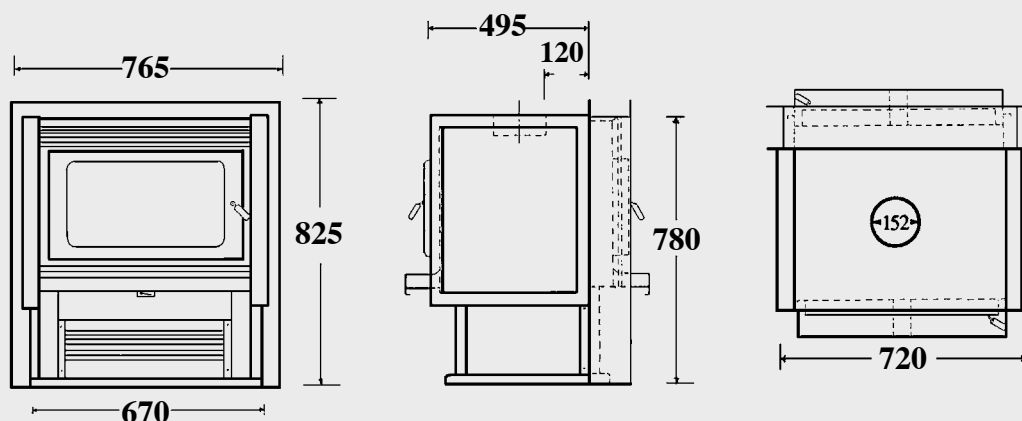

Technical Specifications

The Kemlan Coupe range consists of three unique double sided models:

1. **Freestanding model**
2. **Wall penetration model**
3. **Insert model**

This unique double sided heating system was designed by Kemlan so the fire can be enjoyed in more than one room while distributing heat evenly throughout the home.

All models are available with an optional two speed fan.

Clean

- Environmentally friendly.
- Complies to AS / NZS 4012 / 4013 for clean emission output.
- Preheated primary airwash system ensures a clean view of the fire from both sides.

Simple

- Trouble free operation.
- One easy slide control for steady controllable heat.
- No levers, rods or dampers.
- Easy to light.

Safe

- Tested to AS / NZS 2918 for safety clearances.
- Fully shielded convection system.
- Optional 2 speed fan.

Efficient

- High heat output.
- Natural convection system.
- Optional 2 speed fan.

Robust

- 6mm welded steel firebox.
- Firebrick lined floor.
- Removable heavy duty baffle plate.
- Heavy duty door hinges.
- Serviceable door handle assembly.
- Stainless steel glass holder.

HRL Technologies test report no. RF/93/060
Fuel type - Hardwood.

Heating capacity of this appliance is given as a guide only and may vary depending on the climate zone and type of dwelling - (floor plan and degree of insulation).

Consult your local authorised distributor to determine realistic expectations for your home.

Heat output and fuel consumption of this appliance is dependant on the moisture content, size, loading geometry and the type of hardwood used.

Performance

Heating capacity - 170 -240m² (18-25 squares)
Peak heat output - 14.6kW
Average emission output - 4.0g/kg

Colour choices

Satin Black, Charcoal, Golden fire Brown, Mettalic Moss Green, Mettalic Brown, Pewter, Titanium, Metallic Blue and Forrest Green.

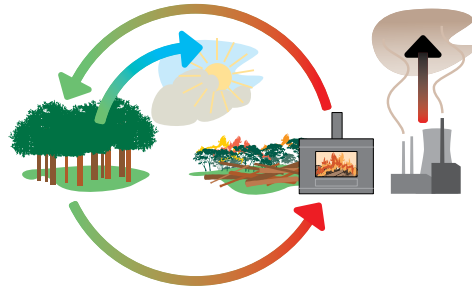

- 1: Burning wood in a Kemlan Bioburn slow combustion wood heater produces efficient home heating energy
- 2: CO² is created by burning wood in fireplaces, bush fires and decomposition. Energy is wasted when wood is burnt in bush fires or decomposes
- 3: CO² is absorbed by trees when growing
- 4: O² is released into the atmosphere resulting in reduced greenhouse gas emissions
- 5: Kemlan supports the Firewood Association of Australia Firewood merchants accredited by the F.A.A are able to supply sustainable dry fuel for use in efficient approved fireplaces. Use of sustainable dry fuel will not cause adverse air quality
- 6: Burning fossil fuels such as coal fired electricity, oil and gas adds to greenhouse gas emissions

BURN RATE

AVERAGE	HIGH	MEDIUM	LOW
Heat output (kW)	9.9	5.8	4.7
Fuel consumption (kg/hr)	3.6	1.9	1.4

10 year firebox warranty

The firebox is covered by a 10 year warranty.
Other parts are covered by a one year limited warranty.

Showroom Open
Mon-Fri 9am-5pm,
Sat 9am-1pm

**FIREPLACE
CORNER**

277 Lord Street, Perth | 08 9228 2600
sales@fireplacecorner.com.au
www.fireplacecorner.com.au



KEMLAN is a subsidiary of
Jetmaster Fireplaces Aust P/L.

