

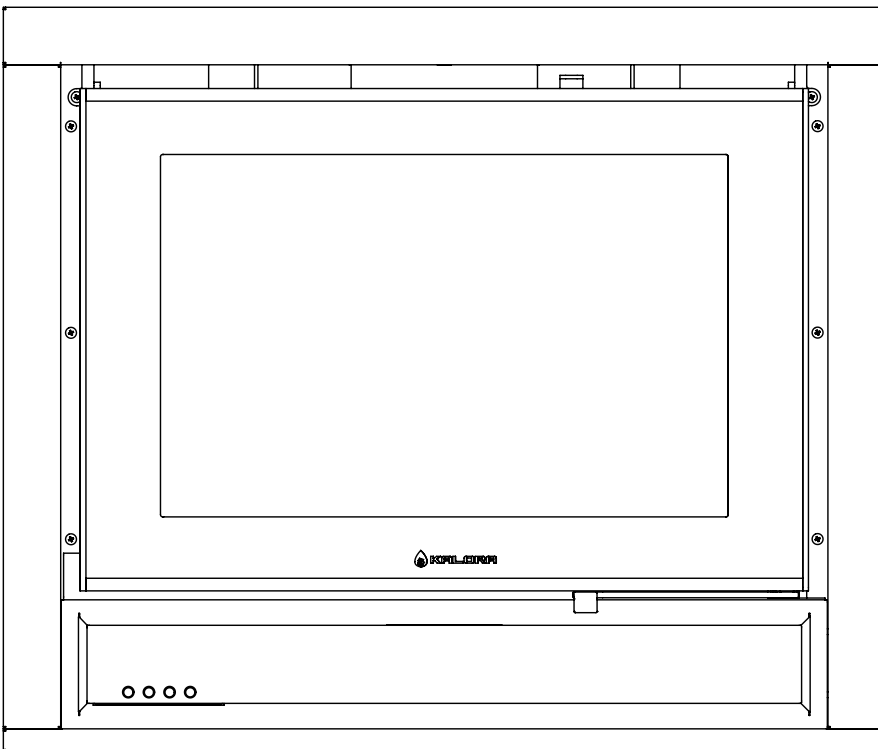

ACCENT INBULIT USER MANUAL



Kalora (Aust) Pty Ltd

Head Office
58 Access Way
Carrum Downs, VIC 3201
Australia

+61 3 8579 5905
info@kalora.com.au
www.kalora.com.au

Version1.5b 02/06/2023

Contents of manual may be updated without notice.
For the latest version of this manual please refer to our website: www.kalora.com.au

KALORA INBUILT RANGE

Model Name **Model Number**

Accent **SG010400172**

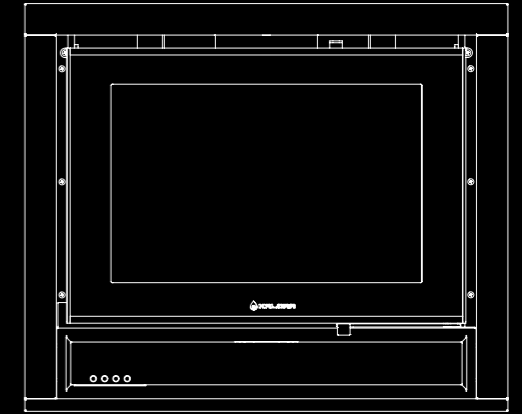

CONTENTS

| | |
|------------------------------------|----|
| Wood heater safety | 4 |
| Before installing your wood heater | 5 |
| Installation | 6 |
| Operating your wood heater | 10 |
| Wood heater maintenance | 12 |
| Trouble shooting | 14 |
| Exploded diagram | 15 |
| Spare parts list | |
| Warranty | 16 |

INTRODUCTION

Congratulations on purchasing a genuine Kalora Wood heater. When cared for properly, these high quality, finely crafted wood heaters will offer many years of reliable performance. This instruction manual has been developed to ensure optimum performance from your Kalora wood heater. It's very important that you thoroughly read and understand all instructions before using your new wood heater.

COUNCIL REQUIREMENTS

Check Local Council Requirements Eg. permits

When installing, operating and maintaining your wood heater, follow the guidelines presented in these instructions, and make them available to anyone using or servicing the wood heater.

Your city, town, state or territory may require a building permit to install a solid fuel burning appliance. Always consult your local building inspector or local council to determine what regulations apply in your area.



Please note:

Your wood heater must be installed by a qualified person whose work conforms with local council regulations, Australian standards & manufacturers recommendations. Failure to do so will void your warranty and could possibly void any home insurance.

WOOD HEATER SAFETY

When properly maintained and operated your wood heater should give you many years of service, however there are important safety aspects of these products that you need to be aware of when operating a wood heater.

1. This appliance is not intended for use by persons (including children) with reduced physical, sensory or mental capabilities, or lack of experience and knowledge, unless they have been given supervision or instruction concerning use of the appliance by a person responsible for their safety.
2. Children should be supervised to ensure that they do not play with the appliance.
3. If the electrical supply cord is damaged, it must be replaced by the manufacturer, its service agent or similarly qualified persons in order to avoid hazard.
4. Never place combustible items such as but not limited to furniture, fabric or wood within the specified clearances to combustibles.
5. The burning of wood gives off gases which can be extremely dangerous. Wood heaters are designed so that under normal operating circumstances these gases pass up the flue chimney system and cannot escape into your home, however it is important that your flue system is properly installed and that you check all joints regularly to ensure that there are no cracks or gaps, check the door sealing rope and replace when damaged/worn. We recommend a smoke alarm be fitted in rooms where wood heaters are installed. Do not use your wood heater in a room where negative pressure conditions exist. Negative pressure environments can cause products of combustion to be drawn from the fireplace into the room. Caution should be taken when using any form of extraction in a room where a wood heater is installed.
6. This appliance is designed to specifically burn dry hardwood. Do not burn rubbish, driftwood, flammable liquids or any substance containing salts or corrosives.
7. Creosote and soot may accumulate in your flue pipe and chimney. This may ignite, causing a chimney fire. If you suspect a chimney fire close down the air controls on the wood heater, if the fire persists evacuate people from the building and call the Fire Brigade. To prevent the accumulation of soot or creosote, check flue and chimney regularly and clean as necessary. Good burning, hot wood heaters will generally cause a lot less build-up than slow burning wood heaters, likewise dry wood will cause less build-up than wet wood. We recommend a fire extinguisher be available where wood heaters are in operation. In the event of a chimney fire do not re-light the wood heater until the heater and the flue chimney system have been thoroughly checked and repaired/replaced as necessary.
8. Wood heaters get extremely hot and should not be touched when lit. When young children are in the area, we recommend the use of a suitable fire guard around the wood heater. Always wear protective gloves when reloading wood heater.
9. Never over-fire your wood heater. If external parts of your wood heater are glowing red then the wood heater is over-firing and your draught settings should be reduced. Never interfere with the draught mechanisms or adjust your air settings outside those limits set when the wood heater is manufactured. Never use a secondary fan to supply or extract air to the wood heater.
10. All users of the wood heater should be aware of the contents of this manual. Please leave this manual where it is accessible to wood heater users and do not allow anyone to use the wood heater that is unfamiliar with its correct operation.
11. Never use the wood heater if any parts are missing or damaged, only use genuine parts as replacements. Never modify your wood heater.

BEFORE INSTALLING YOUR WOOD HEATER

You need to consider the following to ensure the safe operation of your wood heater:

- Provision of adequate air to support efficient combustion of the fuel.
- A well sealed flue/chimney system, hereinafter referred to as the "flue system".
- The protection of combustible materials in proximity of the wood heater.
- A suitable base on which to place your wood heater.

ADEQUATE PROVISION AIR

It is essential for the safe and efficient use of your wood heater that you provide an adequate air supply to your wood heater.

This may mean the provision of an outside air supply to the room, especially if there are extraction units such as cooker hoods or clothes dryers in the vicinity. Failure to do so will mean that fuel is burned inefficiently causing smoke, blackening the glass and may also cause smoke to come back into the room. As a simple check for this open a door or window in the room and check if the wood heater burns more efficiently.

WELL SEALED FLUE SYSTEM

Under no circumstances should you use aluminum or galvanized steel pipes for your wood heater flue. Always fit pipes with the narrow crimped side down, this allows any creosote to run down the inside of the pipe and not to come out and cause an unsightly mess and possible fire hazard.

Pipe bends should be kept to a minimum and we do not recommend using more than 2 bends on any installation. Flues must not pass through ceilings, floors, attics, roofs, or combustible walls without adequate and approved insulation being provided to protect combustible materials.

The chimney and flue provide a means of taking combusted fuel from the wood heater, as well as a draught to enable the wood heater to work. It is essential that the flue system is kept in good condition and there are no breaks or cracks allowing contact with any other combustible materials of the house. It is also essential that the flue system is kept clean and seals are maintained to ensure the draught is not lost. The open end of the flue system must be above the height of the apex of the building and any other obstructions, such as trees, which are within 3 meters (10ft) of the flue system. Failure to do this will affect the efficiency of the wood heater and may cause down draughts which will mean dangerous products of combustion are emitted into the room.

Under no circumstances should the flue pipe be less than 6" (152mm) internal diameter.

CLEARANCES TO COMBUSTIBLES

It is extremely important that you respect required installation distances and that you respect local installation regulations.

This is for your safety! The manufacturer is not responsible for the product, if it is not installed following these recommendations. These clearances may only be reduced by means approved by the regulatory authority.

A combustible surface is anything that can burn (i.e. plaster, wall paper, wood, fabrics etc.) These surfaces are not limited to those that are visible and also include materials that are behind non-combustible materials. If you are not sure of the combustible nature of a material, consult your local fire officials.

HEARTH REQUIREMENTS

The floor protector must consist of 40mm thick cement fibre sheet which has a thermal resistance of 0.17m² K/W, per 4mm thickness or equivalent. Kalora have a complete range of suitable ready to install hearth pads for straight wall and corner installations.

Manufacturers recommendation: Keep all combustible materials at least 1.22 metres (4 feet) away from the appliance. This include rugs, fabrics, furnishings, papers, firewood, etc. NEVER dry clothing on or within 1.22 metres of the appliance.

UNIT DIMENSIONS

Heater

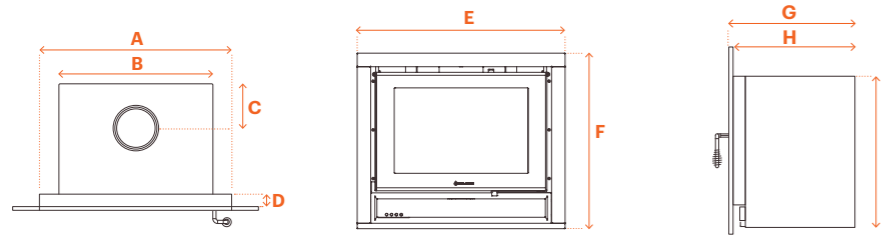

Clearance box

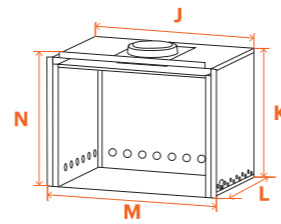

ACCENT

| | | |
|---|---|-------|
| A | Rear side of fascia width | N/A |
| B | Firebox casing width | 672mm |
| C | Rear of firebox casing to centre of spigot | 167mm |
| D | Rear of fascia thickness | N/A |
| E | Fascia width | 769mm |
| F | Fascia height - Floor Mount: 629mm or Wall mount: 649mm | |
| G | Depth overall | 493mm |
| H | Depth from rear of firebox casing to rear of fascia | 480mm |
| I | Firebox casing height | 592mm |
| J | Zero clearance box casing width | 790mm |
| K | Zero clearance box casing height | 658mm |
| L | Depth of clearance box | 555mm |
| M | Width of clearance box front | 844mm |
| N | Height of clearance box front | 686mm |

INSTALLATION

FOR CONNECTING INTO EXISTING MASONRY CHIMNEY:

- Any chimney should be fully intact with no holes or missing bricks.
- The top of the chimney must be sealed using a chimney plate which should be sealed in place with a mortar mix.
- Active flue should be trimmed in line with the top of the chimney if it meets the minimum height requirements under AS/ NZS 2918.
- If additional lengths are required to fulfill this requirement these lengths must be cased.
- The flue should always be finished with a cowl and cone.

PLEASE NOTE:

- There should not be any active flue exposed to the elements.
- When installing your appliance in a masonry chimney, the appliance must have a minimum 10mm clearance around the unit to allow for thermal expansion.

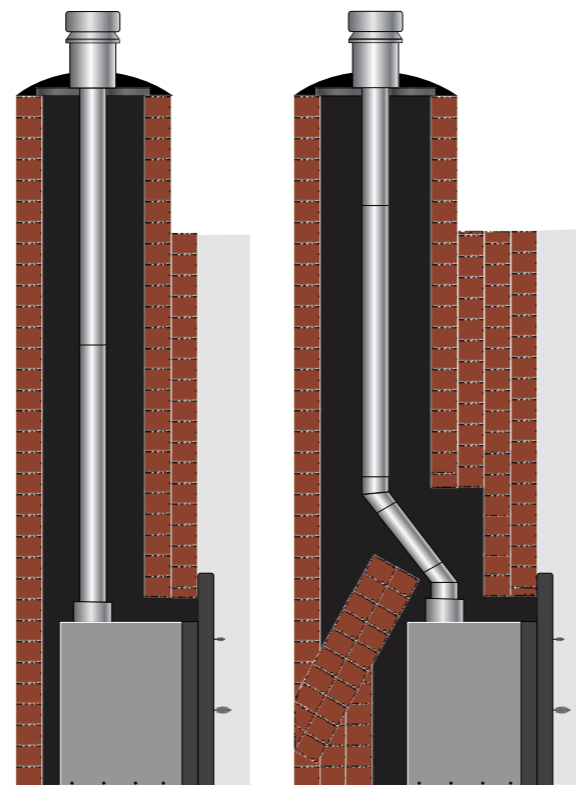

INSTALLATION ...continued

MINIMUM INSTALLATION CLEARANCES

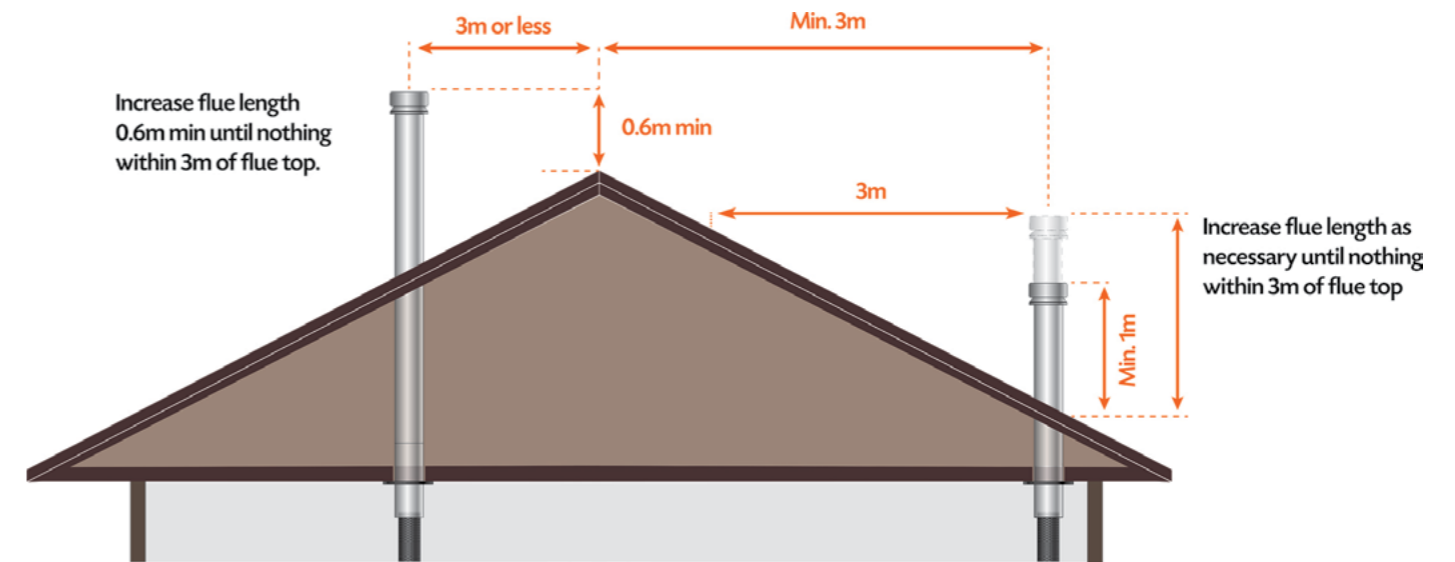

FIGURE 1

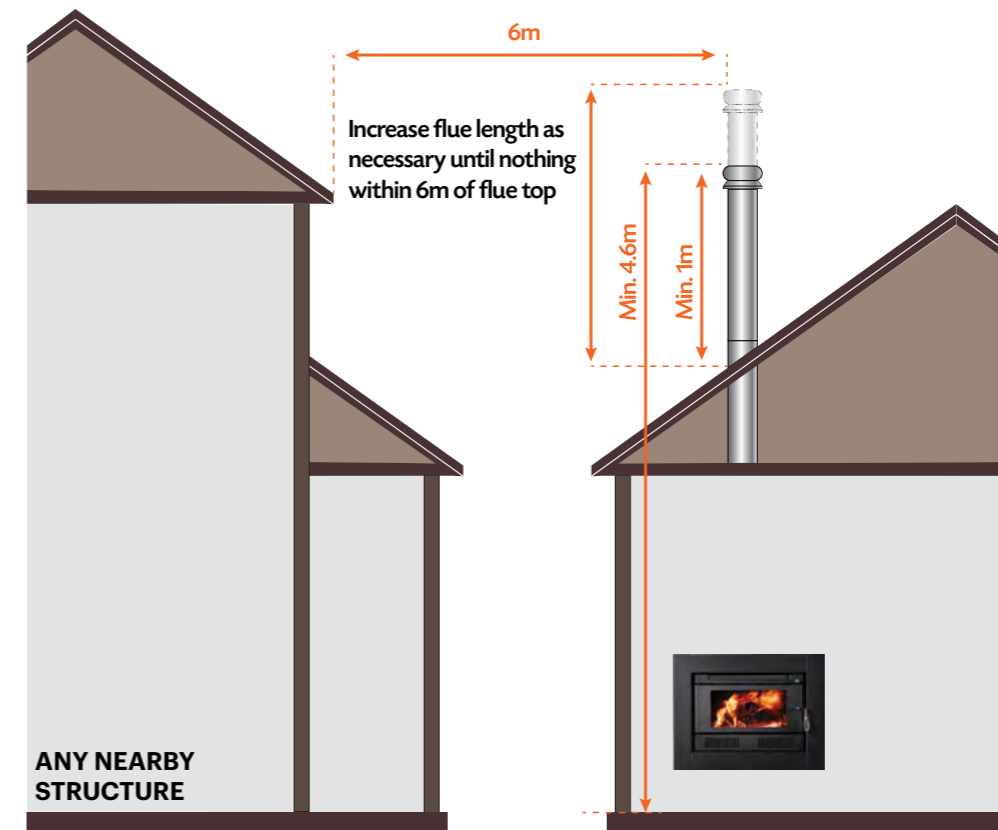
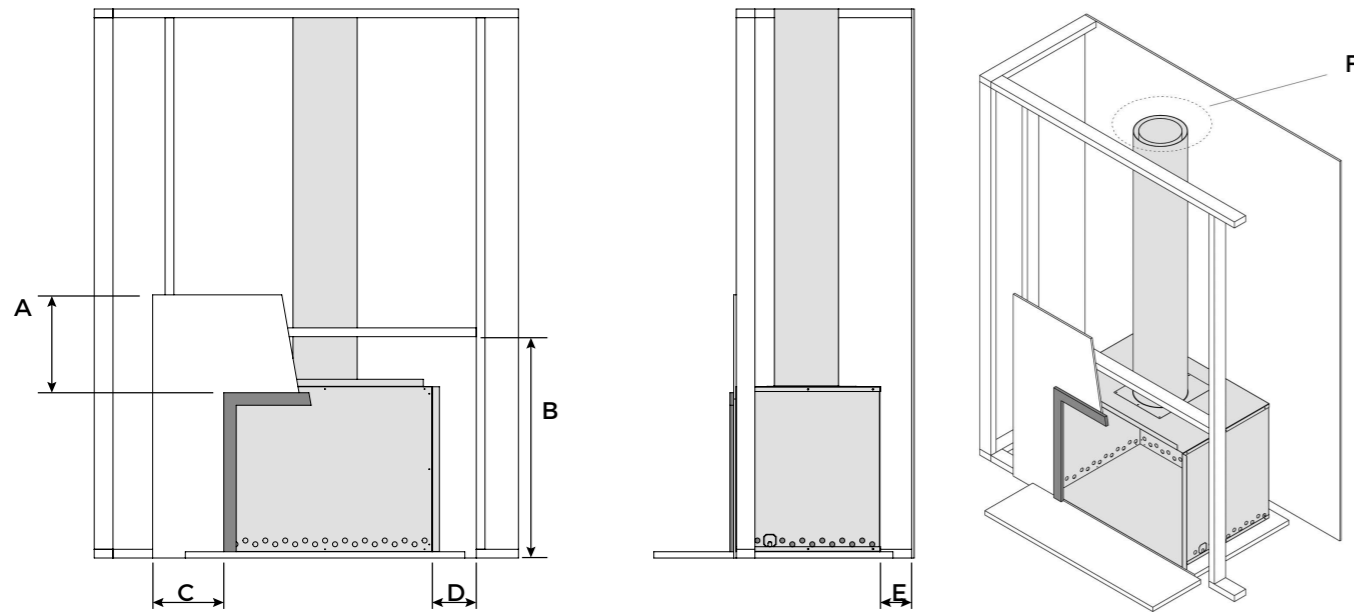

FIGURE 2

INSTALLATION ...continued

CLEARANCES

The following clearances are only applicable when installed with a Kalora Zero Clearance Box (SG010400052). Applicable to each appliance. Diagrams are for illustrative purposes only and are not to scale.



ACCENT

| | | |
|----------|--|-------------|
| A | Fire-rated board fascia minimum height <small>In some cases, fascia might be larger/smaller than illustration. Always measure distance from the edge of the fascia.</small> | 485mm |
| B | Internal noggin above the appliance from floor protector | 1145mm |
| C | Fire-rated board extension beyond the appliance | 65mm |
| D | Side of outer casing of zero clearance box to combustible material | 55mm |
| E | Rear of outer casing of zero clearance box to combustible material | 55mm |
| F | Ceiling hole must be evenly spaced around the flue casing to ensure adequate ventilation for the appliance. | 610mm (min) |

IMPORTANT:

ACCENT:

A 50mm air gap must be maintained around the outer triple flue skin in the ceiling of the enclosure. First internal wall stud must be no closer than 80mm to the flue outer casing.

VENTILATION PORTS

To provide adequate air flow, venting in the ceiling of the enclosure around the triple skin flue must be minimum of 242,000mm² evenly spaced around the outer flue casing. Refer to AS/NZS 2918:2018.

INSTALLATION ...continued

CLEARANCES

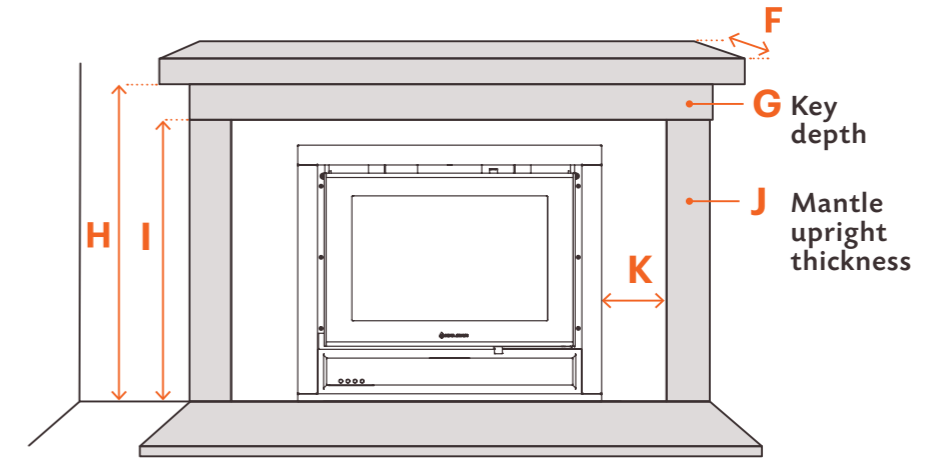

ACCENT

| | | |
|----------|--|--------|
| F | Mantle Shelf Depth | 250mm |
| G | Mantle key depth | 45mm |
| H | Floor protector to mantle shelf | 1330mm |
| I | Floor protector to mantle key | 1160mm |
| J | Mantle upright maximum thickness | 45mm |
| K | Minimum distance to the mantle upright | 70mm |

HEARTH REQUIREMENTS

ACCENT

A minimum 645mm deep x 900mm wide x 40mm thick floor protector should be used under the appliance, a minimum 920mm wide x 550mm deep x 25mm thick floor protector must be used in front of the appliance base when installing the appliance.

INSTALLATION ...continued

FIREBOX ASSEMBLY:

1. Remove all loose items from the fire box. First install the top baffle. Place the baffle in the firebox with the bent edges facing the same direction as in the below drawings.
2. Lift the front edge of the baffle up and rest it on the top of the front baffle support lugs, continue to lift the rear of the baffle over the rear lugs, you will need to slide the baffle forward to clear the rear lugs.
3. Once the rear of the baffle is above the rear lugs slide the baffle all the way to the back of the firebox and rest the rear of the baffle on the rear lugs, ensuring the baffle is touching the rear wall of the firebox.
4. Next install the firebricks. First install the side and rear firebricks, place the firebrick retainer in place on the top of the firebricks as shown in the below diagram.
5. Install the base firebricks. Push side firebricks all together leaving any gap at the front of the heater. Push rear firebricks together leaving any gaps even on each side. Push base firebricks together leaving even gap around outside.

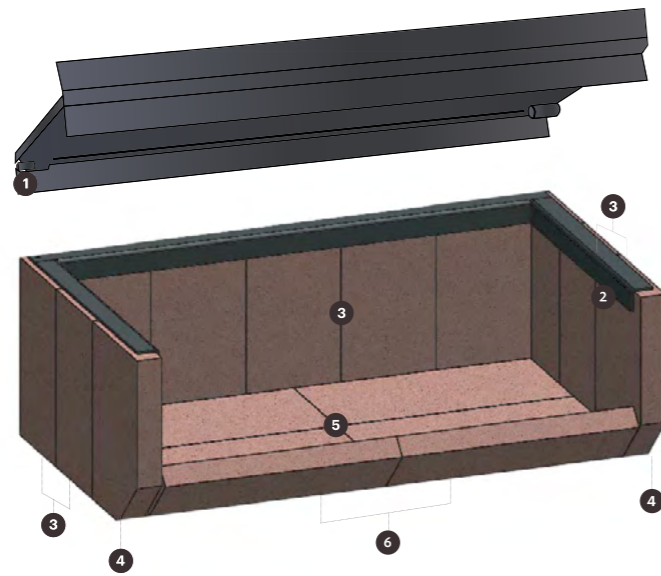

| LEGEND | PART | QTY | PART NO. |
|--------|--|-----|-------------|
| 1 | Top Baffle | 1 | SG030700263 |
| 2 | Firebrick Retainer | 1 | SG030700269 |
| 3 | Firebrick Rear/Side - 108x200x28 | 9 | |
| 4 | Firebrick Side Corner Cut - 136x200x28 | 2 | |
| 5 | Firebrick Bottom - 130x269x25 | 4 | |
| 6 | Firebrick Ash Ledge - 70x269x25 | 2 | |
| | Firebrick Set | | SG030600024 |

INSTALLATION ...continued

ZERO CLEARANCE BOX INSTALLATION(SG010400052)



1 Lay down bottom panel folded edges facing upwards and non folded edge to the front.

2 Screw inner left, inner right and inner back panels together, returns facing outwards.

3 Screw inner top panel in place.



4 Screw 8" collar in place.

5 Screw outer left, outer right and outer rear panels in place with vent holes to the bottom, returns facing outwards.

6 Screw outer top panel into place.
1 x Large return facing upwards at the front.
3 x Small returns facing downwards.



7 Screw 10" collar into place.

8 Use plastic installation covers where fan cord passes through inner and outer panels.

Triple skin flue must be installed from zero clearance box as per Australian Standards. A 25mm clearance from the outer 10" casing to any combustible material must be maintained.

OPERATING YOUR WOOD HEATER

CONTROLS AND THEIR USE

- | | |
|---|---|
| 1 | Power cable for fan operation |
| 2 | 3 Speed push button fan control |
| 3 | Air Slide to control primary air intake |
-

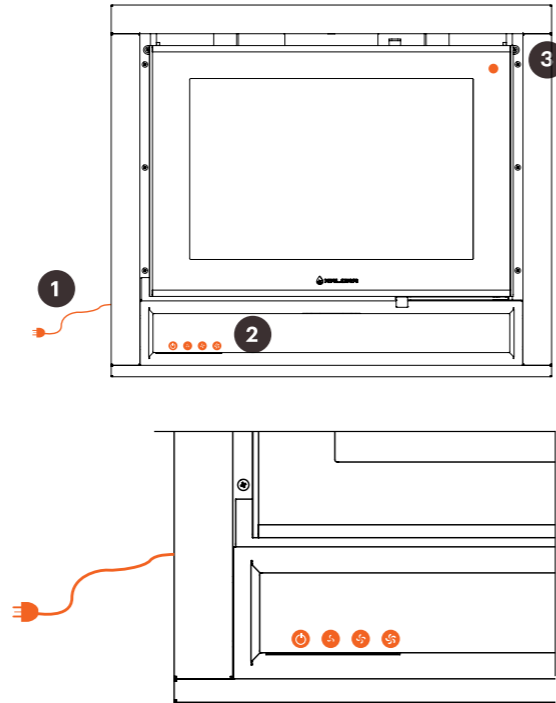

FAN OPERATION

- | | |
|--------|-------------------------------------|
| Step 1 | Plug heater into a power outlet |
| Step 2 | Press ON/OFF button |
| Step 3 | Press 3 speed fan button as desired |

FUEL

Your wood heater is designed to burn dry hardwood only.

It is **NOT** designed to burn the following:

- Soft wood
- Treated or painted wood
- Paper or cardboard, other than small amounts used to light stove.
- Plastics
- Synthetic fuel or logs that are not approved for solid fuel stoves
- Household rubbish
- Liquid fuels

Burning these or other products for which the wood heater was not designed may damage the wood heater and cause a fire hazard or release toxic fumes.

Fuel should be stored in a dry place; wood should be dried for at least 1 year and have a moisture content of less than 20%. Wet wood may cause serious creosote build up, which may damage your flue system and even your wood heater. Therefore the use of green, sappy or wet wood is strongly discouraged.

LIGHTING THE FIRE

Open the fire door, lay a few crumpled sheets of paper or firelighters on the firebox base then a few small dry pieces of sticks or kindling, open the air inlet controls. Now light the paper, close the fire door when the kindling has caught fire (allow about 10 minutes for this to happen) add larger pieces of dry wood, until the fire box is half filled. When the larger pieces of wood have caught fire, add full sized logs. Close the air controls to the point where the required burn rate is obtained.



WARNING: FIRST OPERATION OF WOOD FIRE

When operating, this unit will get extremely hot. Do Not Touch, use tools where necessary. You should begin using your wood heater by lighting small fires which get progressively larger. We recommend lighting approximately 5 small fires before you put the wood heater into full service. Allow the wood heater to fully cool between each of these fires. There may be some smell and a small amount of smoke from the wood heater during the initial operations. This is perfectly normal and is merely the curing of the wood heater paint. Opening a window or door to provide additional ventilation will help alleviate this.

OPERATING YOUR WOOD HEATER ...continued

AIR CONTROLS

Your wood heater needs air to burn the fuel. This air is supplied through a primary air slide at the right side of the front of your wood heater above the door. On the ACCENT secondary air is drawn into the top rear of the firebox which is not adjustable.

Primary air, as the name suggests, is used for the initial burning of the fuel and is also used to keep the stove glass clean. Secondary air is used for secondary combustion, which makes the stove more efficient and reduces emissions.

The settings of the primary air control very much depends on draught and local conditions and after a few fires, you should have a good idea of the best settings for your wood heater. The air slide control should be fully opened when lighting the fire. Once the fire is established, the air slide control may be adjusted as required. Reducing the air intake will cause the wood heater to burn slower. This may cause some blackening of the stove glass, but this should burn off once the wood heater is burning brightly again.

REFUELING

Before refueling your wood heater, turn the air supply to high for a few moments until there is a good fire in the heater. This will ensure there is no build-up of harmful gases in the wood heater when the door is opened and will also get the new fuel burning quickly and not allow it to kill the fire. Open the door slowly in case any logs or coal have fallen against the glass. Opening the door quickly may result in smoke being drawn into the room.

To reload the wood heater, open the door and feed the fuel in slowly always using either tongs, a small shovel along with protective gloves. Do not overfill the wood heater. It is always better to put in small loads often rather than big fills less frequently. Wood should be loaded in a front to back direction, this helps air flow as well as reducing the risk of logs falling forward. Close the door gently after wood heater is reloaded.

OVERNIGHT BURNING

Your wood heater is designed to maximise burn times. Best results are achieved when you establish a good fuel bed in the wood heater and allow it to burn for about 30 minutes before closing the air slide control fully.

When you return to your wood heater, fully open the air slide control until you have a good fire and then set to normal operating levels. Do not add fuel until the fire bed is hot and red. Then add a little for the first time and allow that to ignite before adding more. During overnight burning, the wood heater glass may blacken, but when a hot fire is established again this should burn off.

ACCENT

The ACCENT comes fitted with the fascia. In the case you need to remove the fascia, only the six screws need to be removed:

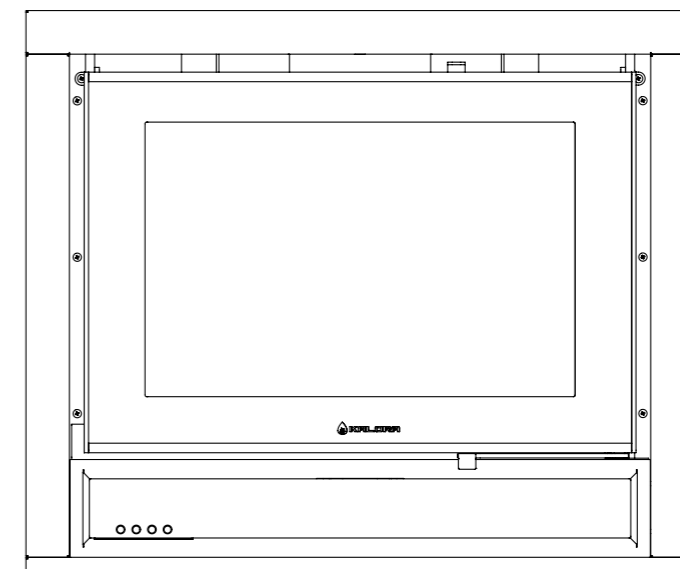

WOOD HEATER MAINTENANCE

CHECK YOUR WOOD HEATER REGULARLY

Initially, we recommend you check your flue system at least once per month. After the first few months you will notice a pattern of soot and creosote build up and you can then determine an inspection interval for checking soot and creosote build up that is suitable for your wood heater installation.

Other checks, as listed below, should be carried out at least twice per year. If you notice anything wrong at any time it should be repaired immediately. Never use a wood heater that is in any way damaged or has a damaged flue.

1. Check your flue system for build up of soot or creosote and for signs of damage to joints.
2. To check flue outlet remove top of baffle by lifting and pulling out at end. Use a flashlight to check flue outlet.
Clean and repair as necessary. Always replace top baffle before relighting stove.
3. Check that glass is not cracked or chipped and that the sealing rope is in good condition.
Replace as necessary.
4. When the room is dark, use a strong flashlight to check the sealing of the wood heater at the edge and corners for leaks. Any leaks or cracks found should be repaired with fire cement or damaged parts should be replaced with genuine spare parts.
5. During periods in inactivity or infrequent use, regularly alternate the position of the flue damper. We also recommend placing a silica bag in the firebox to absorb any moisture which may cause rust.
6. Check that wood heater door is tight and well sealed when closed. Place a strip of paper into the wood heater and close the door, try to pull out paper. You should feel some resistance to your pull, check several points around the door. If it pulls out too easily, replace the rope and seal in place with a suitable high temperature sealant.
7. Check baffle plate and firebricks. Baffle plate should be replaced if a hole appears in the surface of the plate. Firebricks should be replaced when they start to crumble or the firebox is exposed.

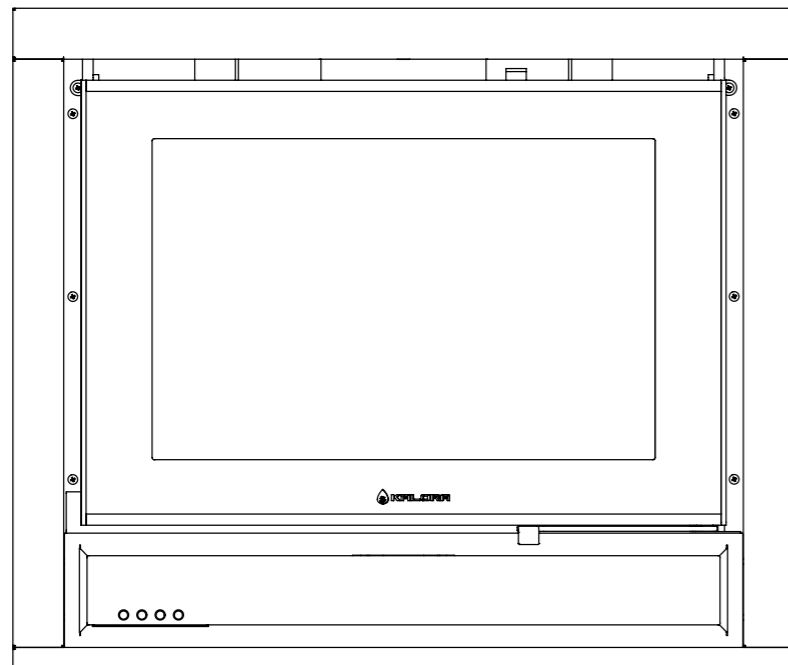

WOOD HEATER MAINTENANCEcontinued

ASH REMOVAL

When the stove is out and completely cold you may remove the ash using an ash vacuum or a steel bucket with a lid and shovel. Place a cover over the bucket so that when removing the bucket the ash does not blow about your house.

CARE OF GLASS

At times, especially when the air controls are turned to low settings or when damp wood is used, the wood heater glass will blacken. This is caused by fuel that is not completely burnt, but the build-up on the inside of the glass will normally burn off when a good hot fire is established in the wood heater.

There may be times however when you need to clean the glass. To do this, use a soft cloth and a non-abrasive glass cleaner.

Only ever clean the glass when the wood heater is cold. For best results select from Kalora's range of glass cleaning products. When loading fuel into the wood heater, always make sure it is not protruding out through the door opening, as this may break the glass when you close the door. This is especially relevant when loading logs. Always close the door gently.

If the glass does crack when the wood heater is lit, let the fire die out. Do not open the door until the wood heater has fully cooled. Replace the glass with the specified replacement part before re-using the wood heater.

DOOR ADJUSTMENTS

1. Open & remove door
2. Remove fascia
3. Remove the bolts mounting the roller latches, 2 per latch
4. Remove one spacer at a time from both latches to allow the door to close tighter against seal
5. Store spacers in a safe place
6. Refit latches
7. Refit door and check for seal, place a piece of paper in between door seal and sealing edge
8. If paper can not be slid out, there is sufficient seal. if paper can be slid out repeat steps 3 thru 7
9. Once all spacers have been removed and door still does not seal, replace seal & refit spacers.
10. Refit front fascia and door

REPLACING PARTS

Always use genuine replacement parts. Only ever make replacements when the wood heater is cold. All replacement parts can be ordered from www.kalora.com.au.

SURFACE FINISH

To clean your heater wipe lightly with a damp cloth or dust with a duster. Some cleaning products may leave stains on the wood heater surface. Never use abrasive cloths as these may scratch the surface; take caution when using microfiber cloths as they can leave swirl marks if used in a circular motion. Painted wood heaters can be re-painted by using a good quality, high temperature wood heater paint. When re-painting, make sure there is plenty of ventilation and follow the manufacturer's instructions. Allow the paint to fully dry before lighting the stove and allow extra ventilation for the first couple of fires as some fumes may emit from the stove as the paint cures.

Kalora high temp enamel is available at your local Kalora dealer or visit www.kalora.com.au.

TROUBLE SHOOTING

Many people under estimate the importance of using a professional installer with experience in wood heating who adheres to Australian Standards to install their wood fire.

If you are having issues with your wood fire not working the way you think it should, we implore you to speak to your installer first; they can help you with issues such as burning too much or too little wood, smoke in the room when you open the door, blackened glass or build-up of creosote during use. A professional installer can also provide guidance on whether the problem is a manufacturing issue in this instance we will work with them to resolve any issues as soon as possible for you.

It is important to remember that all flue installations must be compliant with Australian Standards. A heater installed with a non-compliant flue configuration will not perform as advertised or as tested.

FIRE NOT BURNING

A wood heater not burning is generally caused by either a shortage of air and/or incorrect or damp fuel. If fuel is not the problem check:

1. That the air controls are opened.
2. There is no blockage in the flue system.
3. That the open end of the flue is above the height of any nearby obstructions.
4. That there is a sufficient air supply into the room and that this supply is not being taken by an extractor fan.

GLASS BLACKENS

Glass usually blackens when:

1. The fuel is not being burned efficiently because of starvation of air.
2. Bad quality or damp fuel is being used.

Please note: For optimum efficiency always use a good quality dry hardwood.

SMOKE IN ROOM

If the wood heater is properly installed it should not emit any smoke into your room. Should this happen, check that your room is not air tight. This can easily be checked by opening a door or window. If the smoking stops you need to provide an additional air supply into the room. If this is not the problem, check if your chimney is blocked or obstructed and that you are not getting a down draught caused by the location of the open end of the flue pipe or chimney.

If the problem persists contact your installation company and ask them to get your chimney and stove installation checked.

FIRE BURNING TOO QUICKLY

This is usually caused by too much draught or air.

1. Firstly try reducing the air supply to the wood heater by closing down your air controls, if this fails then you may have to adjust the door or you may have damage to the sealing.
2. Close a thin strip of paper in the door, check to see if the paper stays in place or pulls out. If the paper pulls out easily you may need to adjust or replace the door seal.
3. Check to see if the glass moves within the door frame. If it does you may need to tighten the glass retainer screws.
4. Check the condition of the door sealing rope and the glass seal tape.

TROUBLE SHOOTING ...continued

CHIMNEY FIRE

Chimney fires occur when soot and creosote that have built up in the flue system ignite. If the wood heater is operated properly and the flue checked and cleaned regularly then chimney fires should not occur.

These fires can be very dangerous and must be avoided. Try to maintain good, hot fires in the wood heater whenever possible and at least once in every firing open the air controls and allow the wood heater to burn on full for a short while until the entire fire bed is glowing red.

Check your flue system regularly for build-up of soot and creosote and clean as necessary. Chimney fires can be detected by sparks coming from the top of the chimney, a roaring sound coming from the area of the stove or chimney or vibration in the stove or chimney. In the event of a chimney fire, close the air controls, evacuate the building and call the fire department. Do not relight the stove after a chimney fire until the stove and flue have been checked and any necessary repairs have been carried out.

ACCENT EXPLODED DIAGRAM

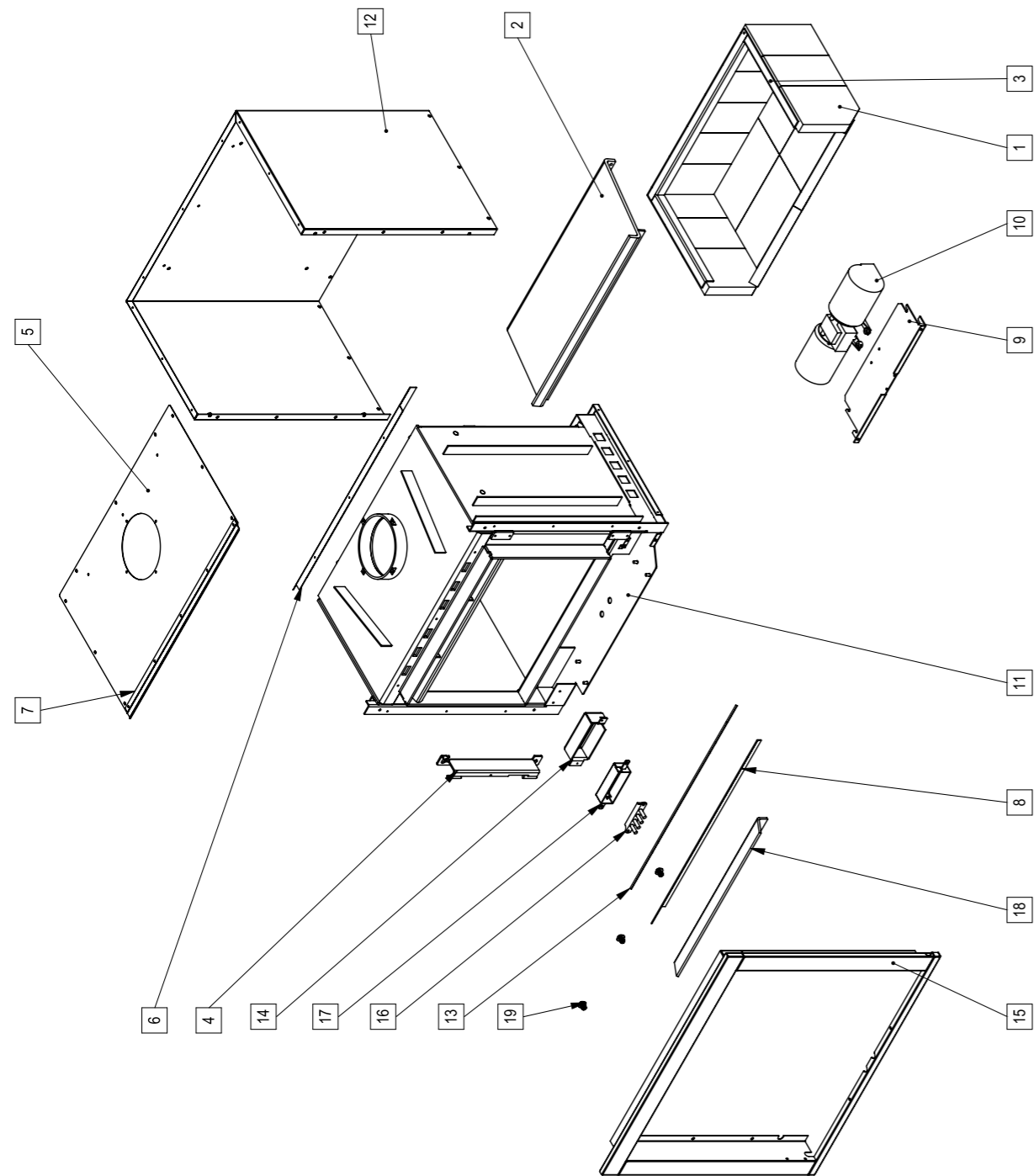

ACCENT EXPLODED DIAGRAM

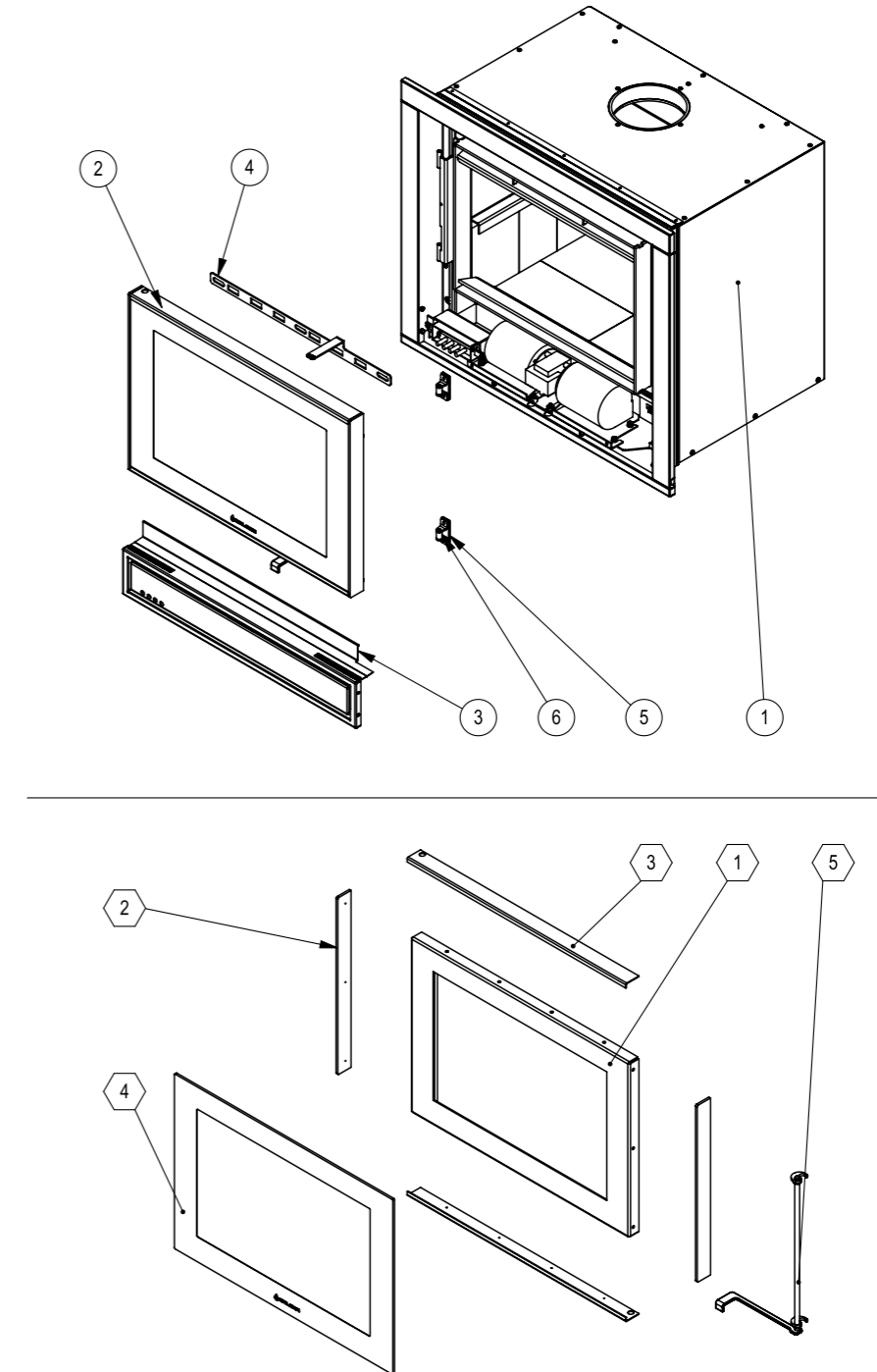

ACCENT SPARE PARTS LIST

SG031000148
KALORA ACCENT, HEATER SUB ASSY, MINUS DOOR ETC PART LIST

| ITEM NO. | PART NUMBER | DESCRIPTION | QTY. |
|----------|-------------|------------------------------------|------|
| 1 | SG030600024 | Set Firebrick Accent | 1 |
| 2 | SG030700263 | Baffle Weldment Accent | 1 |
| 3 | SG030700269 | Retainer Firebrick Accent MS | 1 |
| 4 | SG030700273 | Door Hinge Bracket | 1 |
| 5 | SG030700271 | Top heat shield | 1 |
| 6 | SG030700270 | Rear top air deflector Accent | 1 |
| 7 | SG030700807 | Cover Plate Fascia Top Accent | 1 |
| 8 | SG030700808 | Separation Plate for Fan Room | 1 |
| 9 | SG030700809 | Fan Mounting Plate Accent | 1 |
| 10 | SG030800045 | ROOM FAN ASSY, OPTION LIST | 1 |
| 11 | SG030700817 | Firebox Assy MS Accent | 1 |
| 12 | SG030700810 | Heat Shield Main Accent | 1 |
| 13 | SG030600037 | Insulation Board Fan Room Accent | 1 |
| 14 | SG030700811 | Housing for Push Button Accent | 1 |
| 15 | SG030700256 | Fascia Mid-Mount Accent | 1 |
| 16 | SP00044 | Push Button | 1 |
| 17 | SG031000146 | Base Push Button | 1 |
| 18 | SG030700262 | Deflector Lower Air Wash MS Accent | 1 |
| 19 | SG031300118 | Kit Fasteners Air Slide | 3 |

SG010400172
KALORA ACCENT, HEATER ASSEMBLY PART LIST

| ITEM NO. | PART NUMBER | DESCRIPTION | QTY. |
|----------|-------------|---|------|
| 1 | SG031000148 | ACCENT, HEATER SUB ASSY, MINUS DOOR ETC | 1 |
| 2 | SG030700825 | KALORA, ACCENT, DOOR ASSY | 1 |
| 3 | SG030700820 | KALORA, ACCENT, LOWER FASCIA PANEL | 1 |
| 4 | SG030700818 | KALORA, ACCENT, AIRSLIDE | 1 |
| 5 | SG030700819 | KALORA, ACCENT, LATCH SPACER | 6 |
| 6 | SPMR512B | Door Latch on Body Black | 2 |

SG030700825
KALORA ACCENT, DOOR ASSY PART LIST

| ITEM NO. | PART NUMBER | DESCRIPTION | QTY. |
|----------|-------------|---|------|
| 1 | SG030700826 | KALORA, ACCENT, DOOR, FRAME | 1 |
| 2 | SG030700827 | KALORA, ACCENT, DOOR, OUTER SIDE PANEL. | 2 |
| 3 | SG030700828 | KALORA, ACCENT, DOOR, OUTER TOP/BOTTOM PANEL. | 2 |
| 4 | SG031000149 | ACCENT, DOOR GLASS | 1 |
| 5 | SG030700829 | KALORA, ACCENT, DOOR, LOCK MECHANISM | 1 |

INSTALLATION

FOR CONNECTING INTO A STANDARD INSTALLATION USING KALORA FLUE KITS

The following drawing is meant as a guide only. Your wood heater must be installed by a qualified person whose work conforms with local council regulations, Australian/New Zealand standards (AS/NZS 2918:2018) & manufacturers recommendations.

Kalora wood heaters are independently tested to Australian Standards using a Kalora flue kit, we always recommend using a Kalora flue kit when installing a Kalora wood fire.

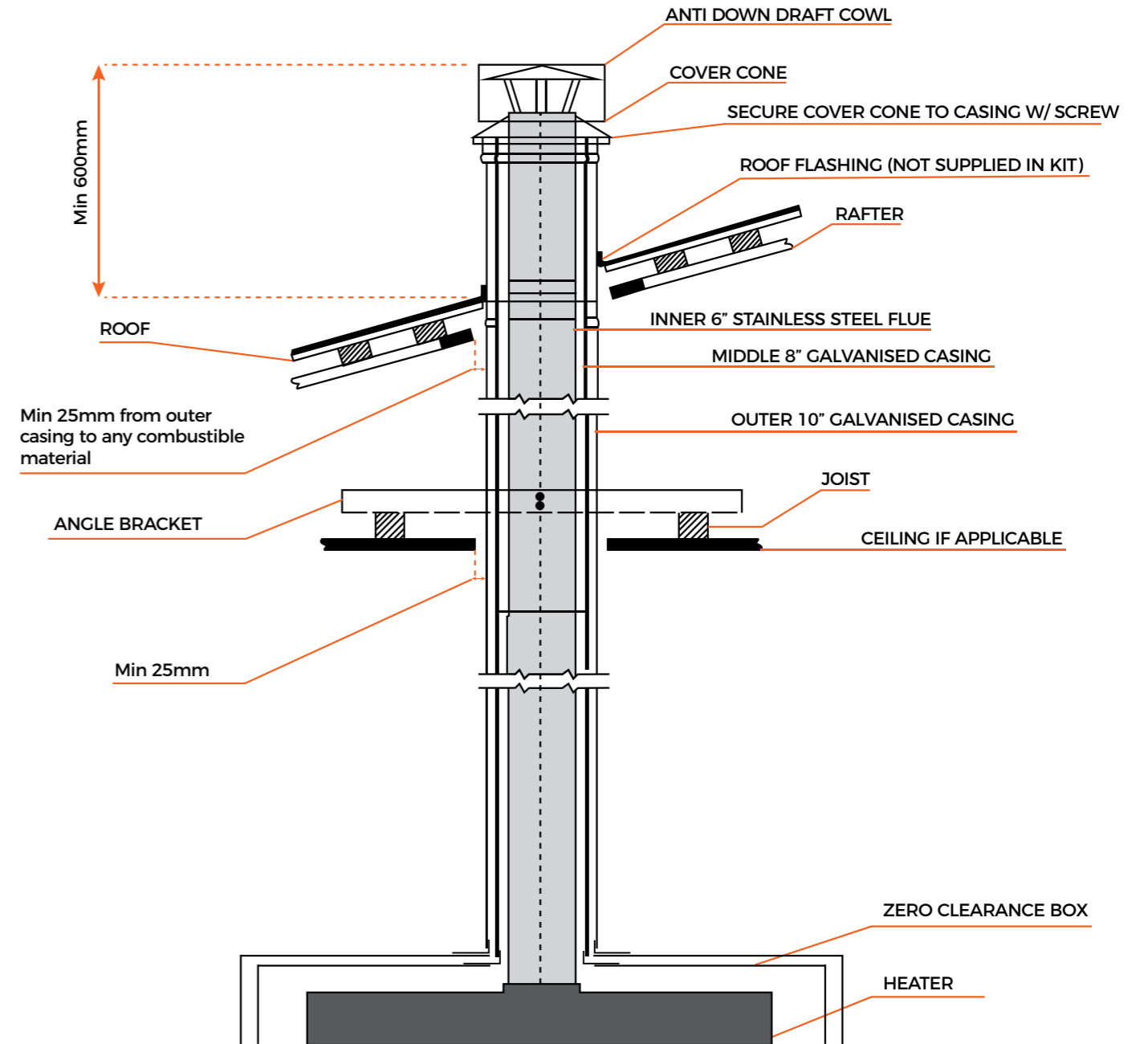

WARRANTY

KALORA LIMITED WARRANTY

This limited warranty is given by Kalora Pty Ltd (ACN 142 881 141) (Kalora or we) to the original retail purchaser (you) of the wood heater to which this Warranty applies.

Our goods come with guarantees that cannot be excluded under the Australian Consumer Law. You are entitled to a replacement or refund for a major failure and for compensation for any other reasonably foreseeable loss or damage. You are also entitled to have the goods repaired or replaced if the goods fail to be of acceptable quality and the failure does not amount to a major failure.

The benefits that this Warranty provides are in addition to other rights and remedies available to you under the Australian Consumer Law. This Warranty does not limit those rights and remedies.

SCOPE OF WARRANTY

If a defect in material or workmanship appears in the following parts within the corresponding warranty period after the date of the original purchase, such as to make the wood heater unfit for normal home use; and you comply with the requirements below regarding making a claim, then, subject to the exclusions below, we will replace or repair the relevant part or (at our option) replace the entire wood heater with the same or comparable model.

| PART | WARRANTY PERIOD |
|--|-----------------|
| Firebox | 15 Years |
| All other parts (Including dampers, liners and fire-brick retainers) | 1 Year |

To the extent permitted by law, our liability under this Warranty is limited to this replacement or repair obligation.



IMPORTANT

For this Warranty to apply, you must fully complete the Warranty Registration Form via kalora.com.au. Alternatively you can complete the Warranty Registration Card and mail it to our mail address (below) within 30 days after the original purchase. By completing this form, you also agree that, to the extent permitted by law, our liability to you on any basis in relation to the wood heater (other than under the Australian Consumer Law) is limited to our obligations under this Warranty.

WARRANTY ...continued

EXCLUSIONS

This Warranty does not apply:

1. Where the defect is not due to the original design or manufacture of the part (including where the wood heater, part or accessory has been subject to accident, abuse, alteration, misuse or neglect or has been installed, inspected, operated or maintained negligently or not in accordance with applicable local laws and regulations and the manufacturer's printed instructions, if any)
2. Where the firebricks, top baffle or fibreglass seal have not been replaced after becoming damaged or worn
3. To any accessories or optional parts.
4. To any glass, paint, firebrick, fibreglass seal sold or used with the wood heater.
5. To any surface rust which may occur in transit, storage or use.
This includes installations in close proximity to coastal areas and salt water which may cause rust to the appliance.

HOW TO MAKE A CLAIM

Any claim under this Warranty must be in writing to our mail address below. It must be sent within the applicable warranty period and must state:

1. The model and serial number of the wood heater
2. The place, price and date of purchase
3. Reasonable details of the defect

To obtain replacement or repair under this Warranty, the wood heater must be returned to the original place of purchase (and collected from there once the replacement or repair is complete) at your cost. Kalora will not be responsible for any associated freight, disconnection or re-installation costs (including labour costs). Kalora will only be responsible for transport of the wood heater from the original place of purchase to Kalora's premises (and back), and replacement or repair in accordance with this Warranty.

REGISTER YOUR PRODUCT



REGISTER BY MAIL

Alternatively, please complete the attached warranty card within 30 days of installation and return to:

Kalora (Aus) Pty Ltd.
58 Access Way, Carrum Downs
Victoria, Australia, 3201



Kalora Pty Ltd
58 Access Way, Carrum Downs
Victoria 3201
Australia